

# M

MAMMUT



## GUIDA AI PRODOTTI PRODUCT PROFILE



**Cattini**  
OLEOPNEUMATICA





## MANUFACTURERS SINCE 1967

"Mammut" is a brand by Cattini Oleopneumatica, a leader manufacturer company which has been working in Automotive and Mining sector for almost 50 years, enjoying a constant qualitative and technological growth and able to offer an extremely wide range of products.

Each jack is made with special prime quality material and inspected and tested before leaving our storages.

This makes Mammut range a perfect solution for all our customers needs.

*"Mammut" è un noto marchio di proprietà della Cattini Oleopneumatica srl, azienda leader nella produzione che opera nel settore automotive e minerario da 50 anni, esprimendo una crescita qualitativa e tecnologica costante e in grado di offrire una gamma estremamente ampia di prodotti.*

*Ciascun sollevatore è costruito con materiali di primissima qualità ed è ispezionato e testato prima di essere spedito dai nostri magazzini.*

*E' questo che rende la gamma Mammut una soluzione ottimale per tutte le esigenze dei nostri clienti.*



**Cattini**  
OLEOPNEUMATICA

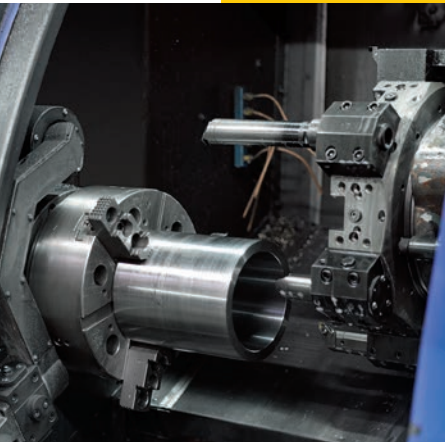

#### QUALITY CONTROL

The quality, in our opinion, starts with the choice of materials that are accurately selected and provided with technical data sheets certifying the technical and mechanical features as well as the chemical analysis.

But the process does not stop here: it follows the machining and assembly phases till the presentation of the final product. This allowed us to guarantee our jacks during the time, offering reliability and success.

#### ASSEMBLY

All Mammut jacks, accesories and equipment are locally produced by Cattini quality assurance personnel oversight.

The external design together with the engineering employed by Cattini staff is completely focused on safety and economic efficiency.

#### FINAL TEST AND INSPECTION

Each single jack made undergoes final testing and inspection for more than an hour with automatic devices besides the ordinary tests established by the European Standards. It is then checked once again to guarantee its perfect working order.

#### CONTROLLO QUALITÀ

*La qualità, secondo ciò in cui noi crediamo, nasce dalla scelta dei materiali, accuratamente selezionati e accompagnati da schede prodotto certificanti specifiche tecniche, meccaniche e relative analisi chimiche.*

*Ma non si esaurisce in questa fase; accompagna la lavorazione fino alla presentazione del prodotto finito. Questo ci ha permesso di garantire i nostri sollevatori nel tempo, assicurando affidabilità e serietà.*

#### ASSEMBLAGGIO

*Tutti i sollevatori Mammut, gli accessori e le attrezzature sono prodotti localmente, sotto la supervisione del dipartimento tecnico dell'azienda.*

*Il design esterno insieme all'ingegneria utilizzata dal personale sono interamente indirizzati alla sicurezza e all'efficienza economica.*

#### COLLAUDO

*Ogni singolo sollevatore prodotto viene collaudato per oltre un'ora con dispositivi automatici, oltre alle normali prove imposte dalla Normativa Europea, e successivamente ricontrollato per garantire il perfetto funzionamento.*



# QUALITY CONSTANT CONTROL



# WE KNOW HOW

## DESIGN

The research for maximum product quality is guaranteed by the high level of professionalism and experience, combined to the high level of professionalism of our staff. All the designs stages are performed inside the company, using extremely advanced computerized systems, 3D technical softwares, vector converter softwares.

## WORKING THE RAW MATERIAL

The working of each single item is done completely inside the company using numerically controlled machinery boasting extremely high technology, quality and precision. Once the first stages are finished, the product is ready to be treated with thermic treatments.

## WAREHOUSE

Displaced on total area of 4500sqm., our warehouse is a mix of modernity and efficiency. The computer-controlled management ensures us the prompt delivery of any jack.

## ECO SUSTAINABILITY

Sustainability, the new way of doing business, an ethical commitment for a better environment. Producing in Italy is synonymous with processes conforming to the strictest laws in the world. And it is for this reason that we have invested a lot, improving our products with a keen eye on the environment.

We paint our products with eco friendly materials and our new painting unit is designed and made to use water-based paint.

## PROGETTAZIONE

*La ricerca della massima qualità scaturisce da un elevato grado di professionalità e esperienza sul campo, unita alla grande professionalità del nostro personale. Tutte le fasi della progettazione sono eseguite internamente utilizzando sistemi informatici estremamente avanzati, software di grafica 3D e programmi vettoriali.*

## LAVORAZIONE MATERIE PRIME

*La lavorazione dei singoli particolari è eseguita interamente all'interno dell'azienda utilizzando macchinari a controllo numerico di altissima qualità e precisione. Terminati i primi passaggi, il prodotto è pronto per trattamenti termici superficiali.*

## STABILIMENTO

*Dislocato su un'area complessiva di 4500mq., risulta essere un giusto mix di modernità ed efficienza. Dalla gestione altamente informatizzata, permette la consegna rapida di qualsiasi tipo di sollevatore.*

## ECOSOSTENIBILITÀ

*Sostenibilità, un nuovo modo di fare impresa, un impegno etico per un ambiente migliore. Produrre in Italia significa avere processi conformi alle legislazioni più restrittive del mondo. Proprio per questo abbiamo investito molto, migliorando i nostri prodotti con un occhio di riguardo per l'ambiente. I nostri prodotti sono verniciati con materiali ecologici e il nuovo impianto di verniciatura interno è stato progettato e realizzato appositamente per la verniciatura ecologica ad acqua.*

## WARRANTY

At Cattini, all efforts are made to assure our products meet high quality and durability standards. The Mammut range is covered by a 12 month warranty, valid from the date appearing on the purchase document. The warranty certificate can be found in the end user manual provided along with the shipment.

## GARANZIA

*In Cattini, l'obiettivo principale è focalizzato sulla sicurezza.*

*La gamma Mammut è coperta da 12 mesi di garanzia, valida a partire dalla data indicata sul documento d'acquisto.*

*Il certificato di garanzia può essere trovata nel manuale di utilizzo per l'utente fornito insieme alla spedizione.*

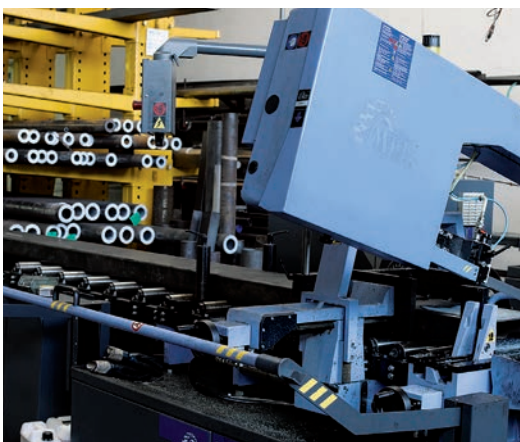



## INTERNATIONAL CONFORMITY

All our products are certified according to the strictest EC standards because the technology in each and every CATTINI product is one of quality and precision combined with the experience of our highly specialized technical staff. This certification originates from the design: it is not applied only to the finished product but is innate in each single detail that make up our lifts.





## COMPANY CERTIFICATION AND EVOLUTION

Our company is ISO 9001 QUALITY MANAGEMENT SYSTEM certified.

To provide a performance that comes up to expectations, certification guarantees that all the products, starting from their design, going through production, assembly and testing, are made in absolute compliance with current standards.

All our jacks are constantly evolving.

In fact each time there is a change decreed by technological progress, we take it upon ourselves to use it to improve our strategic strong points because even though a product works well we have to see to it that it works even better.

We always keep a keen eye on what happens in the world. And in the case of particular demands we know just how to respond with new models or by improving the existing ones.

## PRODUCT CERTIFICATION

As testimony to our company's strong commitment towards a quality policy, our products conform to the directives 93/44EEC, EN1494, 98/37/EEC, 2006/42/EEC and EAC.

## CERTIFICAZIONE ED EVOLUZIONE AZIENDALE

La nostra azienda è certificata ISO 9001 SISTEMA GESTIONE QUALITÀ.

Per fornire prestazioni all'altezza delle aspettative la certificazione garantisce che tutti i prodotti, a partire dalla progettazione, passando per la produzione, l'assemblaggio e il collaudo, sono costruiti nel più assoluto rispetto delle normative vigenti. Tutti i nostri sollevatori sono in costante evoluzione.

Proprio per questo adottiamo tempestivamente ogni cambiamento imposto dal progresso tecnologico impegnandoci per mettere perfettamente a punto i nostri punti di forza strategici, perché se un prodotto funziona bene, dobbiamo fare in modo che funzioni ancora meglio.

Siamo sempre molto attenti a quello che accade nel mondo. Se vi sono esigenze particolari, sappiamo rispondere con nuovi modelli o con l'evoluzione di quelli esistenti.

## CERTIFICAZIONE PRODOTTI

A testimonianza del forte orientamento della nostra azienda verso la politica della qualità i nostri prodotti sono conformi alle direttive 93/44EEC, EN1494, 98/37/EEC, 2006/42/EEC e EAC.

# EAC



Certificato No. 112560A

## CONVERSION TABLE TABELLA DI CONVERSIONE

Length Lunghezza		Inches Pollici (in)	Millimeter Millimetri (mm)		
	<b>1 in</b>			25,4	
<b>1 mm</b>		0,0394			
Mass Massa		Pounds Libbre (lb)	Kilograms Chilogrammi (kg)	Metric ton Tonnellata (t)	Short ton Tonnellata americana (ton)
	<b>1 lb</b>		0,4536	0,0004	0,0005
	<b>1 kg</b>	2,2046		0,001	0,0011
	<b>1 t</b>	2204,6	1000		1,1023
	<b>1 US ton</b>	2000	907,18	0,9071	
Pressure Pressione		Bar	Psi		
	<b>1 bar</b>		14,5		
	<b>1 psi</b>	0,069			

## CONFORMITÀ INTERNAZIONALE

Tutti i nostri prodotti sono certificati secondo il più rigido rispetto della normativa CE, perché in ogni prodotto CATTINI la tecnologia si fonde con la qualità, la precisione con l'esperienza del nostro staff tecnico altamente specializzato. Questa certificazione nasce dalla progettazione: non è applicata solamente al prodotto finito ma è innata nei singoli particolari che compongono ogni nostro sollevatore.



## MINING AND SPECIAL APPLICATIONS JACKS



Mammut jacks offer to all customers a solution that is safe and easy to use, suitable for all heavy-duty vehicles from the shop to underground, mining, construction and railroad industries. Available in various models depending on load capacity (from 30 to 150t.) and use, each jack can be configured with a wide range of accessories to meet all demands:

- Load blocking system
- Remote control for working safely
- Various extensions to suit all operations

All models are hydro-pneumatically

operated and equipped with a dual descend valve for greater control when bearing weight and automatic piston return.

For excellent handling during use and transport, each Mammut jack has:

- Folding handle that allows the operator to raise or lower it easily, entering the jack underneath the vehicle
- Wide pneumatic tyres for easy movement on any surface
- Special hook for transport





## SOLLEVATORI DA MINIERA E PER APPLICAZIONI SPECIALI

*I sollevatori "Mammut" offrono a tutti i clienti una soluzione sicura e di facile utilizzo, adatta a tutti i veicoli pesanti dal negozio, alle industrie sotterranee, dalle imprese di estrazione mineraria a quelle ferroviarie.*

*Disponibili in vari modelli a seconda delle capacità (dalle 30t. alle 150t.) e degli utilizzi, ogni singolo sollevatore può essere configurato con una vasta gamma di accessori atti a soddisfare tutte le esigenze:*

- Sistema di bloccaggio del carico
- Comando remoto per operare in sicurezza
- Vari tipi di prolunghe per ogni tipologia di operazione

*Tutti i modelli sono oleopneumatici, con doppia valvola di discesa per un maggior controllo sotto carico e con rientro automatico dei pistoni.*

*Per un'eccellente manovrabilità durante l'utilizzo e il trasporto, ciascun sollevatore dispone di:*

- Manico pieghevole che consente all'operatore di alzarlo o abbassarlo facilmente durante l'inserimento dello stesso sotto il veicolo
- Ampie ruote pneumatiche per un facile spostamento su ciascuna superficie
- Ganci speciali per il trasporto



33



Feuerlöscher I  
Bei Abtrennung  
beide Hebel  
nach vorne ziehen



**M**  
MAMMUT



# AIR HYDRAULIC JACKS

Air hydraulic Mammut jacks are engineered and manufactured to offer to all customers a solution that is safe and easy to use.

For this reason, they offer:

- extremely lightness, compactness and easy movement features
- remote control for safety operations
- folding handle
- wide range of models and capacities from 30t. to 150 t.
- pneumatic tyres for any surface



# SOLLEVATORI OLEOPNEUMATICI

I sollevatori oleopneumatici Mammut sono progettati e costruiti per offrire a tutti i clienti una soluzione sicura e di facile utilizzo.

Per questo presentano:

- caratteristiche di estrema leggerezza, compattezza e maneggevolezza
- comando remoto per utilizzo in sicurezza
- manico pieghevole
- ampia gamma di modelli e portate, dalle 30t. alle 150t.
- ruote pneumatiche per qualsiasi superficie

# M 60/22



## SUITABLE FOR / APPLICAZIONI

Mine and oil field / *Miniere e giacimenti* - Construction site / *Cantieri* - Industrial assembly / *Montaggi industriali* - Agriculture / *Agricoltura* - Railway applications / *Applicazioni ferroviarie* - Military / *Settore militare*



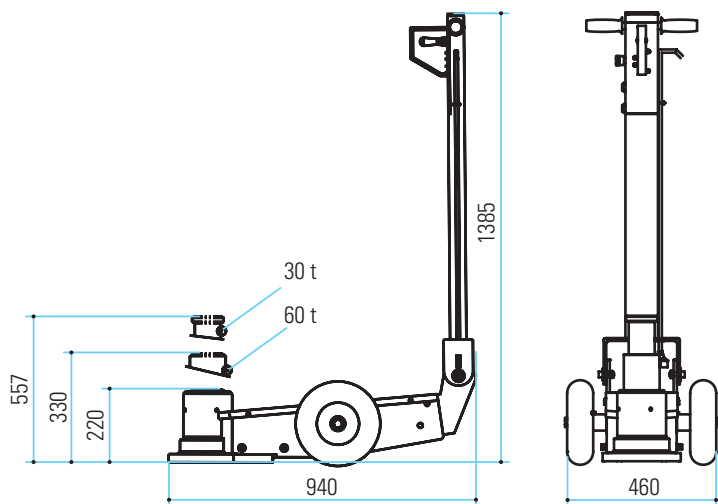

### DATI TECNICI / TECHNICAL DATA

Portata / Capacity	60/30 t 66.1/33.1 ton
Peso netto / Net weight	94 Kg 207 lb
Pressione di alimentazione / Working air pressure	10-12 bar 145-174 psi
Consumo d'aria / Air consumption	600 nl/min
Corsa max. / Max stroke	337 mm 13.3 in
Altezza min. / Min. height	220 mm 8.7 in
Numero Sfili / Number of pistons	2
Corsa Sfili / Pistons stroke	110-227 mm 4.3-8.9 in

### ACCESSORIES / ACCESSORI

A00452	Remote control - Comando Remoto
A02399	Extension Holder R - Portaprolunghe DX
A02400	Extension Holder L - Portaprolunghe SX
A02432	Extension - Prolunga 150 mm
A02434	Extension - Prolunga 250 mm
A02436	Extension - Prolunga 300 mm



### EXTENSIONS - PROLUNGHE

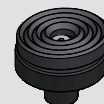

A04492 Tilting Plate - Piattello basculante



A04405 Extension - Prolunga 80mm



A02432 Extension - Prolunga 150mm



A02434 Extension - Prolunga 250mm



A02436 Extension - Prolunga 300mm



A00452 Remote control - Comando Remoto  
M\_60/22

# M 80/31



## SUITABLE FOR / APPLICAZIONI

Mine and oil field / *Miniere e giacimenti* - Construction site / *Cantieri* - Industrial assembly / *Montaggi industriali* - Agriculture / *Agricoltura* - Railway applications / *Applicazioni ferroviarie* - Military / *Settore militare*



A00790

Safety device system - Kit blocchi di sicurezza



- 1 - A02432 Extension - Prolunga 150mm
- 2 - A02434 Extension - Prolunga 250mm
- 3 - A02436 Extension - Prolunga 300mm
- 4 - A02392 Safety Lock Holder - Portablocchi
- 5 - A00835 Safety blocks - Blocco H100 M/F 177mm
- 6 - A00837 Safety blocks - Blocco H100 F/F 177mm
- 7 - A00839 Safety blocks - Blocco H50 M/F 177mm
- 8 - A02399 Extension Holder R - Portaprolunghe DX
- 9 - A02400 Extension Holder L - Portaprolunghe SX



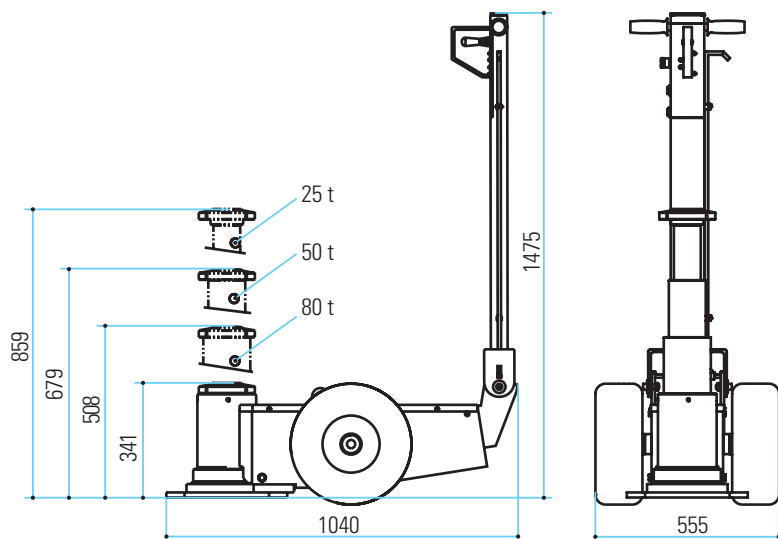

### TECHNICAL DATA / DATI TECNICI

Capacity / Portata	80/50/25 t 88.2/55.1/27.6 ton
Net weight / Peso netto	138 Kg 304 lb
Working air pressure / Pressione di alimentazione	10-12 bar 145-174 psi
Air consumption / Consumo d'aria	600 nl/min
Max stroke / Corsa max.	518 mm 20.4 in
Min. height / Altezza min.	341 mm 13.4 in
Number of pistons / Numero Sfili	3
Pistons stroke / Corsa Sfili	167 - 171 - 180 mm 6.6 - 6.7 - 7.1 in

### ACCESSORIES / ACCESSORI

A00452	Remote control - <i>Comando Remoto</i>
A02399	Extension Holder R - <i>Portaprolunghe DX</i>
A02400	Extension Holder L - <i>Portaprolunghe SX</i>
A02392	Safety Lock Holder - <i>Portablocchi</i>
A00835	Safety blocks - <i>Blocco H100 M/F 177mm</i>
A00837	Safety blocks - <i>Blocco H100 F/F 177mm</i>
A00839	Safety blocks - <i>Blocco H50 M/F 177mm</i>
A02432	Extension - <i>Prolunga 150 mm</i>
A02434	Extension - <i>Prolunga 250 mm</i>
A02436	Extension - <i>Prolunga 300 mm</i>
<b>A00790</b>	<b>Safety Blocks Kit - <i>Kit blocchi di sicurezza</i></b> (Includes - <i>Include: 3xA00835, 1xA00837, 1xA00839, 1xA02392</i> )

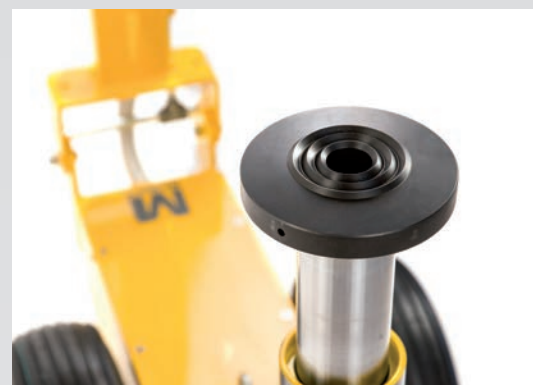

### EXTENSIONS - PROLUNGHE

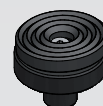

A04492 Tilting Plate - *Piattello basculante*



A04405 Extension - *Prolunga 80mm*



A02432 Extension - *Prolunga 150mm*



A02434 Extension - *Prolunga 250mm*

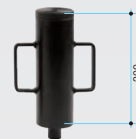

A02436 Extension - *Prolunga 300mm*



A00452 Remote control - *Comando Remoto*  
M\_80/31

# M 80/42



## SUITABLE FOR / APPLICAZIONI

Mine and oil field / *Miniere e giacimenti* - Construction site / *Cantieri* - Industrial assembly / *Montaggi industriali* - Agriculture / *Agricoltura* - Railway applications / *Applicazioni ferroviarie* - Military / *Settore militare*



A00790

Safety device system - Kit blocchi di sicurezza

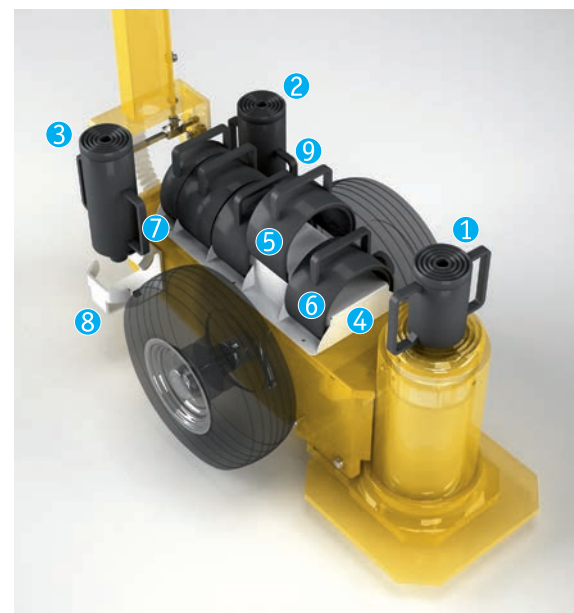

- 1 - A02432 Extension - *Prolunga* 150mm
- 2 - A02434 Extension - *Prolunga* 250mm
- 3 - A02436 Extension - *Prolunga* 300mm
- 4 - A00884 Safety block holder - *Portablocchi*
- 5 - A00835 Safety blocks - *Blocco* H100 M/F 177mm
- 6 - A00837 Safety blocks - *Blocco* H100 F/F 177mm
- 7 - A00839 Safety blocks - *Blocco* H50 M/F 177mm
- 8 - A02399 Extension Holder R - *Portaprolunghe* DX
- 9 - A02400 Extension Holder L - *Portaprolunghe* SX





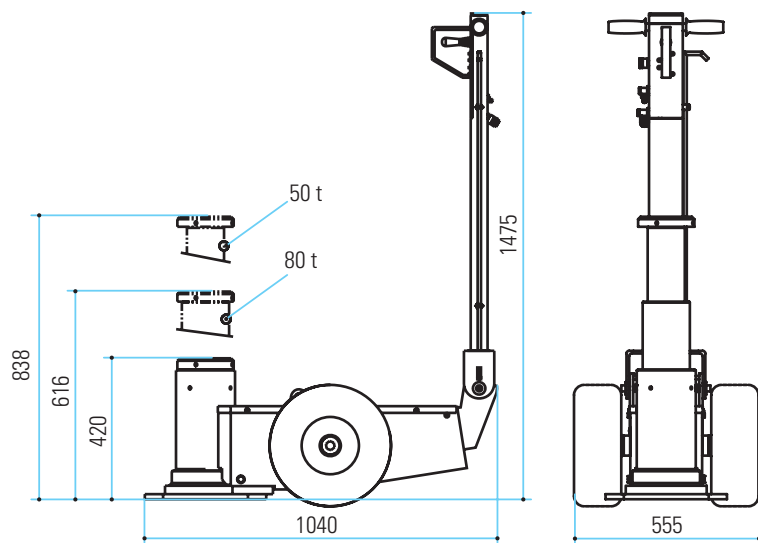

### TECHNICAL DATA / DATI TECNICI

Capacity / Portata	80/50 t 88.2/55.1 ton
Net weight / Peso netto	145 Kg 320 lb
Working air pressure / Pressione di alimentazione	10-12 bar 145-174 psi
Air consumption / Consumo d'aria	600 nl/min
Max stroke / Corsa max.	418 mm 16.5 in
Min. height / Altezza min.	420 mm 16.5 in
Number of pistons / Numero Sfili	2
Pistons stroke / Corsa Sfili	196 - 222 mm 7.7 - 8.7 in

### ACCESSORIES / ACCESSORI

A00452	Remote control - Comando Remoto
A00884	Safety block holder - Portablocchi
A00835	Safety blocks - Blocco H100 M/F 177mm
A00837	Safety blocks - Blocco H100 F/F 177mm
A00839	Safety blocks - Blocco H50 M/F 177mm
A02399	Extension Holder R - Portaprolunghe DX
A02400	Extension Holder L - Portaprolunghe SX
A02432	Extension - Prolunga 150 mm
A02434	Extension - Prolunga 250 mm
A02436	Extension - Prolunga 300 mm

**A00790 Safety Blocks Kit - Kit blocchi di sicurezza**  
(Includes - Include: 3xA00835, 1xA00837, 1xA00839, 1xA00884)



### EXTENSIONS - PROLUNGHE



A04492 Tilting Plate - Piattello basculante



A04405 Extension - Prolunga 80mm



A02432 Extension - Prolunga 150mm



A02434 Extension - Prolunga 250mm



A02436 Extension - Prolunga 300mm



A00452 Remote control - Comando Remoto  
M\_80/42

# M 100/40



## SUITABLE FOR / APPLICAZIONI

Military / *Settore militare* - Mine and oil field / *Miniere e giacimenti* - Construction site / *Cantieri* - Industrial assembly / *Montaggi industriali* - Agriculture / *Agricoltura* - Railway applications / *Applicazioni ferroviarie*



A05102  
Safety device system - *Kit blocchi di sicurezza*

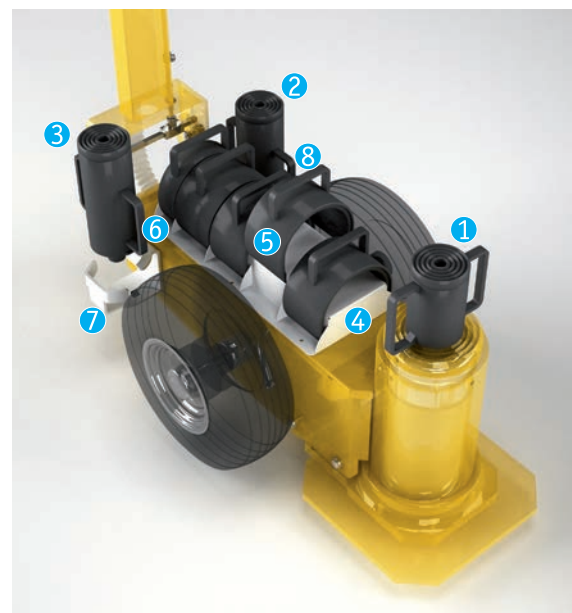

- 1 - A02432 Extension - *Prolunga 150mm*
- 2 - A02434 Extension - *Prolunga 250mm*
- 3 - A02436 Extension - *Prolunga 300mm*
- 4 - A00884 Safety block holder - *Portablocchi*
- 5 - A00835 Safety blocks - *Blocco H100 M/F 177mm*
- 6 - A00839 Safety blocks - *Blocco H50 M/F 177mm*
- 7 - A02399 Extension Holder R - *Portaprolunghe DX*
- 8 - A02400 Extension Holder L - *Portaprolunghe SX*



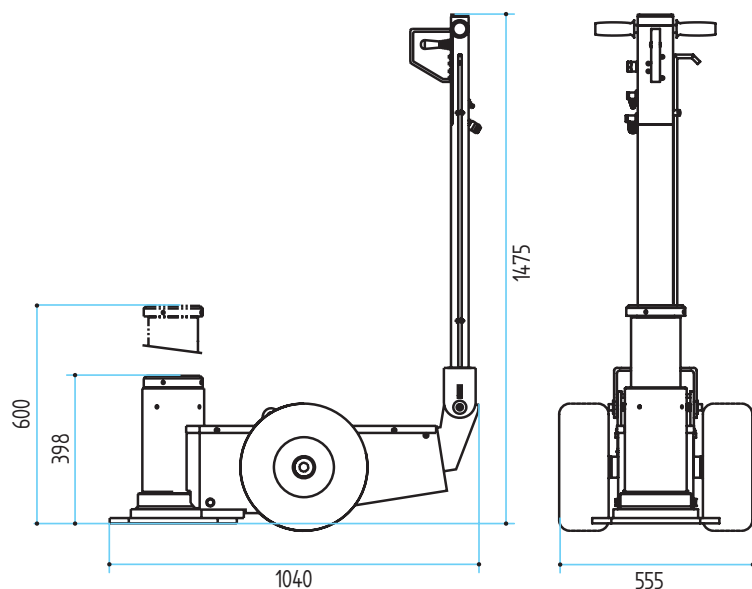

### TECHNICAL DATA / DATI TECNICI

Capacity / Portata	100 t 110.2 ton
Net weight / Peso netto	190 Kg 419 lb
Working air pressure / Pressione di alimentazione	10-12 bar 145-174 psi
Air consumption / Consumo d'aria	600 nl/min
Max stroke / Corsa max.	202 mm 7.9 in
Min. height / Altezza min.	398 mm 15.7 in
Number of pistons / Numero Sfili	1
Pistons stroke / Corsa Sfili	398 - 600 mm 15.7 - 23.6 in

### ACCESSORIES / ACCESSORI

A00452	Remote control - Comando Remoto
A00884	Safety block holder - Portablocchi
A00835	Safety blocks - Blocco H100 M/F 177mm
A00839	Safety blocks - Blocco H50 M/F 177mm
A02399	Extension Holder R - Portaprolunghe DX
A02400	Extension Holder L - Portaprolunghe SX
A02432	Extension - Prolunga 150 mm
A02434	Extension - Prolunga 250 mm
A02436	Extension - Prolunga 300 mm
<b>A05102</b>	<b>Safety Blocks Kit - Kit blocchi di sicurezza</b> (Includes - Include: 1xA00835, 3xA00839, 1xA00884)



### EXTENSIONS - PROLUNGHE

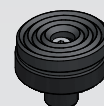

A04492 Tilting Plate - Piattello basculante



A04405 Extension - Prolunga 80mm



A02432 Extension - Prolunga 150mm



A02434 Extension - Prolunga 250mm

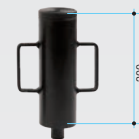

A02436 Extension - Prolunga 300mm



A00452 Remote control - Comando Remoto  
M\_100/40

# M 100/72



## SUITABLE FOR / APPLICAZIONI

Mine and oil field / *Miniere e giacimenti* - Construction site / *Cantieri* - Industrial assembly / *Montaggi industriali* - Agriculture / *Agricoltura* - Railway applications / *Applicazioni ferroviarie* - Military / *Settore militare*



A00788

Safety device system - Kit blocchi di sicurezza



- 1 - A02421 Extension - Prolunga 200mm
- 2 - A02422 Extension - Prolunga 250mm
- 3 - A02423 Extension - Prolunga 300mm
- 4 - A00884 Safety block holder - Portablocchi
- 5 - A00835 Safety blocks - Blocco H100 M/F 177mm
- 6 - A00837 Safety blocks - Blocco H100 F/F 177mm
- 7 - A00839 Safety blocks - Blocco H50 M/F 177mm
- 8 - A02397 Extension Holder R - Portaprolunghe DX
- 9 - A02398 Extension Holder L - Portaprolunghe SX



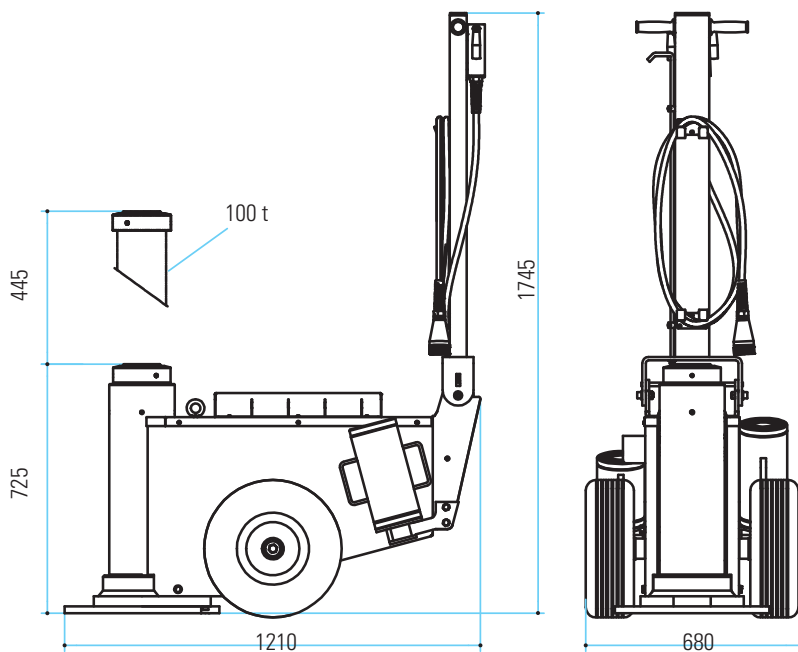

### TECHNICAL DATA / DATI TECNICI

Capacity / Portata	100 t 110.2 ton
Net weight / Peso netto	324 Kg 714 lb
Working air pressure / Pressione di alimentazione	10-12 bar 145-174 psi
Air consumption / Consumo d'aria	600 nl/min
Max stroke / Corsa max.	445 mm 17.5 in
Min. height / Altezza min.	725 mm 28.5 in
Number of pistons / Numero Sfli	1
Pistons stroke / Corsa Sfli	445 mm 17.5 in

### ACCESSORIES / ACCESSORI

A00884	Safety block holder - Portablocchi
A00835	Safety blocks - Blocco H100 M/F 177mm
A00837	Safety blocks - Blocco H100 F/F 177mm
A00839	Safety blocks - Blocco H50 M/F 177mm
A02397	Extension Holder R - Portaprolunghe DX
A02398	Extension Holder L - Portaprolunghe SX
A02421	Extension - Prolunga 200 mm
A02422	Extension - Prolunga 250 mm
A02423	Extension - Prolunga 300 mm

**A00788 Safety Blocks Kit - Kit blocchi di sicurezza**  
(Includes - Include: 3xA00835, 1xA00837, 1xA00839, 1xA00884)



### EXTENSIONS - PROLUNGHE M100/72 - M150/90

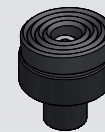

A04495 Tilting Plate - Piattello basculante



A02421 Extension - Prolunga 200mm



A02422 Extension - Prolunga 250mm



A02423 Extension - Prolunga 300mm



Remote control - Comando Remoto  
M\_100/72

# M 150/90



## SUITABLE FOR / APPLICAZIONI

Mine and oil field / *Miniere e giacimenti* - Construction site / *Cantieri* - Industrial assembly / *Montaggi industriali* - Agriculture / *Agricoltura* - Railway applications / *Applicazioni ferroviarie* - Military / *Settore militare*

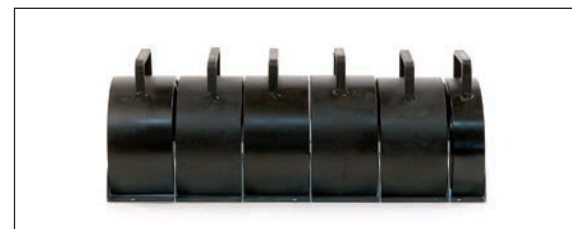

A00789

Safety device system - *Kit blocchi di sicurezza*



- 1 - A02421 Extension - *Prolunga* - 200mm
- 2 - A02422 Extension - *Prolunga* 250mm
- 3 - A02423 Extension - *Prolunga* 300mm
- 4 - A00886 Safety block holder - *Portablocchi*
- 5 - A00841 Safety blocks - *Blocco H100 M/F 177mm*
- 6 - A00843 Safety blocks - *Blocco H100 F/F 177mm*
- 7 - A00845 Safety blocks - *Blocco H50 M/F 177mm*
- 8 - A02397 Extension Holder R - *Portaprolunghe DX*
- 9 - A02398 Extension Holder L - *Portaprolunghe SX*



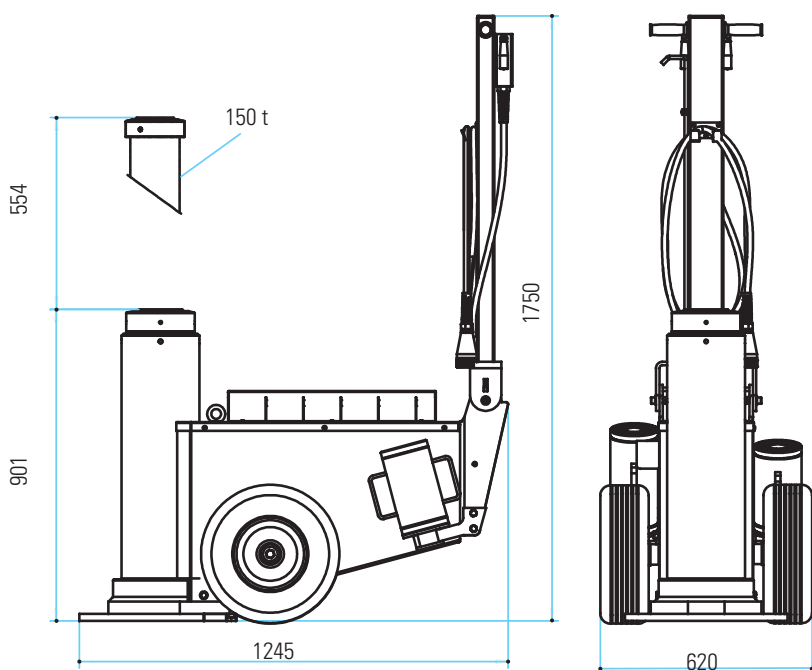

#### DATI TECNICI/ TECHNICAL DATA

Capacity / Portata	150 t 165.3 ton
Net weight / Peso netto	389 Kg 858 lb
Working air pressure / Pressione di alimentazione	10-12 bar 145-174 psi
Air consumption / Consumo d'aria	600 nl/min
Max stroke / Corsa max.	554 mm 21.8 in
Min. height / Altezza min.	901 mm 35.5 in
Number of pistons / Numero Sfli	1
Pistons stroke / Corsa Sfli	554 mm 21.8 in

#### ACCESSORIES / ACCESSORI

A00886	Safety Block Holder - Portablocchi
A00841	Safety blocks - Blocco H100 M/F 216mm
A00843	Safety blocks - Blocco H100 F/F 216mm
A00845	Safety blocks - Blocco H50 M/F 216mm
A02397	Extension holder R - Portaprolunghe DX
A02398	Extension holder L - Portaprolunghe SX
A02421	Extension - Prolunga 200 mm
A02422	Extension - Prolunga 250 mm
A02423	Extension - Prolunga 300 mm

**A00789** Safety Blocks Kit - Kit blocchi di sicurezza  
(Includes - Include: 4xA00841, 1xA00843, 1xA00845, 1xA00886)



#### EXTENSIONS - PROLUNGHE M100/72 - M150/90

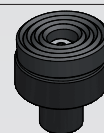

A04495 Tilting Plate - Piattello basculante



A02421 Extension - Prolunga 200mm



A02422 Extension - Prolunga 250mm



A02423 Extension - Prolunga 300mm



Remote control - Comando Remoto  
M\_150/90



**M**  
MAMMUT

**M**  
MAMMUT



# MAMMUT PROFESSIONAL IMPACT WRENCHES: TOP QUALITY INDUSTRIAL SERVICING TOOLS.

Mammut professional impact wrenches stand out for their high performance thanks to the "3-jaw" hammer mechanism and their resistance, as well as the choice of the materials used.

The perfect balance between weight and power allows the operator to work without efforts and with a reasonable low vibration level.

The range of Mammut impact wrenches has been designed to meet the needs of the industrial sector, such as construction sites, shipyards, railways application, infrastructures and industrial assembly.

Moreover, the constant attention to the customers needs led to recently develop a series of ATEX (I M2) certified wrenches for mining, oil and gas sectors.

## QUALITY:

Mammut impact wrenches are engineered and manufactured to withstand rigorous operating conditions both above and below the ground. All our equipments are locally produced and our aim is to ensure an high quality of Mammut wrenches; this is why we test each single item granting safety and efficiency.

Mammut professional impact wrench is:

- Ergonomic
- Compact
- Extremely powerfull
- Perfectly weight balanced

# AVVITATORI PNEUMATICI PROFESSIONALI MAMMUT: UTENSILI INDUSTRIALI DI ALTISSIMA QUALITÀ.

*Gli avvitatori professionali della gamma Mammut si distinguono per le loro elevate prestazioni, grazie al sistema a "tre griffe" perfezionate e alla loro resistenza, così come per la scelta dei materiali utilizzati.*

*Il perfetto equilibrio tra peso e potenza permette all'operatore di lavorare senza sforzi e con un ragionevole livello basso di vibrazioni.*

*La gamma di avvitatori Mammut è stata progettata per soddisfare le esigenze del settore industriale, ovvero quello dei cantieri edili, cantieri navali, ferrovie, infrastrutture e montaggi industriali.*

*Inoltre la costante attenzione alle esigenze dei clienti ha portato al recente sviluppo di una serie di avvitatori con certificazione ATEX (I M2) particolarmente consigliati per il settore minerario, e dell'oil&gas.*

## QUALITÀ:

*Gli avvitatori professionali Mammut sono progettati e costruiti per resistere a condizioni di utilizzo rigorose per ambienti a cielo aperto o sotterranei. Tutte le nostre attrezzature sono di produzione locale e al fine di garantire un livello qualitativo alto, testiamo ciascun elemento per un risultato di estrema sicurezza ed efficienza.*

*L'avvitatore professionale Mammut è:*

- Ergonomico
- Compatto
- Estremamente potente
- Perfettamente bilanciato

# MW38 MW217



SUITABLE FOR / *APPLICAZIONI*  
Trucks, Buses / *Camion, Autobus*



MW38



MW217

ACCESSORIES AVAILABLE / *ACCESSORI DISPONIBILI*



Torque extensions / *Barre di torsione*



Impact sockets / *Chiavi a bussola*



Impact sockets / *Chiavi a bussola*

	MW38	MW217
Square drive / <i>Attacco quadro</i>	3/4"	3/4"
Bolt range / <i>Capacità bullone</i>	M16 - M24	M14 - M24
Ultimate torque / <i>Coppia massima</i>	900Nm / 666 ft-lb	1600Nm / 1184 ft-lb
Working torque / <i>Coppia raccomandata</i>	210-710 Nm / 155-525 ft-lb	320-907 Nm / 237-671 ft-lb
Weight / <i>Peso</i>	2.52 kg / 5.56 lbs	5.95 kg 13.1 lbsW
Working pressure / <i>Pressione di utilizzo</i>	6.5 bar / 94 psi	6,3bar / 91psi
Air inlet / <i>Ingresso aria</i>	1/4" NPT	1/2" BSP
Inner hose diameter / <i>Diametro interno tubo</i>	8 mm / 0.315 in	13mm / 0,512in
Length (without envil) / <i>Lunghezza (escluso albero)</i>	151.5 mm / 5.96 in	182mm / 7,17 in
Side to center / <i>Ingombro centro lato</i>	32.5 mm / 1.28 in	47,5mm / 1,87in
Direzione scarico aria / <i>Air exhaust direction</i>	handle / <i>impugnatura</i>	handle / <i>impugnatura</i>
Anvil type / <i>Tipo albero</i>	with ring, no hole / <i>con anello, senza foro</i>	with ring with hole / <i>con anello, con foro</i>
Hammer mechanism / <i>Tipo massa battente</i>	twin hammer / <i>doppio martello</i>	3-jaw / <i>3 griffe</i>

# MW251L MW246



SUITABLE FOR / *APPLICAZIONI*  
Trucks, Buses /Camion, Autobus /  
Heavy Vehicles /Mezzi Pesanti

## ACCESSORIES AVAILABLE / *ACCESSORI DISPONIBILI*



Torque extensions / *Barre di torsione*



Impact sockets / *Chiavi a bussola*



Impact sockets / *Chiavi a bussola*



	MW251L	MW246
Square drive / <i>Attacco quadro</i>	1"	1"
Bolt range / <i>Capacità bullone</i>	M18-M39	M18-M39
Ultimate torque / <i>Coppia massima</i>	3038 Nm / 2248 ft-lb	2796 Nm / 2069 ft-lb
Working torque / <i>Coppia raccomandata</i>	686-1568 Nm / 508-1160 ft-lb	589-1.373 Nm / 436-1016 ft-lb
Weight / <i>Peso</i>	9.10 kg / 20.06 lbs	8.24 kg / 18.2 lbs
Working pressure / <i>Pressione di utilizzo</i>	6.3 bar / 91 psi	6,3bar / 91psi
Air inlet / <i>Ingresso aria</i>	1/2" BSP	1/2"BSP
Inner hose diameter / <i>Diametro interno tubo</i>	13 mm 0.512 in	13mm / 0,512in
Lenght (without envil) / <i>Lunghezza (escluso albero)</i>	223 mm 8.78 in	249 mm / 9.8 in
Side to center / <i>Ingombro centro lato</i>	56 mm 2.20 in	50 mm / 1.97 in
Direzione scarico aria / <i>Air exhaust direction</i>	handle / <i>impugnatura</i>	handle / <i>impugnatura</i>
Anvil type / <i>Tipo albero</i>	with ring with hole / <i>con anello, con foro</i>	with ring with hole / <i>con anello, con foro</i>
Hammer mechanism / <i>Tipo massa battente</i>	3-jaw / <i>3 griffe</i>	pin-clutch

# MW362H10 MW362H15



## SUITABLE FOR / APPLICAZIONI

Mine and oil field / *Miniere e giacimenti* - Construction site / *Cantieri* - Shipyard / *Costruzioni Navali* - Industrial assembly / *Montaggi industriali* - Agriculture / *Agricoltura* - Railway applications / *Applicazioni ferroviarie* - Military / *Settore militare*

## ACCESSORIES AVAILABLE / ACCESSORI DISPONIBILI



Torque extensions / *Barre di torsione*



Impact sockets / *Chiavi a bussola*



Impact sockets / *Chiavi a bussola*



MW362H10



MW362H15



	MW362H10	MW362H15
Square drive / <i>Attacco quadro</i>	1"	1"1/2
Bolt range / <i>Capacità bullone</i>	M18-M55	M24-M56
Ultimate torque / <i>Coppia massima</i>	5297 Nm / 3920 ft-lb	5933 Nm / 4390 ft-lb
Working torque / <i>Coppia raccomandata</i>	1177 - 2943 Nm / 871-2178 ft-lb	1381 - 3296 Nm / 1022-2439 ft-lb
Weight / <i>Peso</i>	14,76 Kg / 32,54 lbs	14,90 Kg / 32,85 lbs
Working pressure / <i>Pressione di utilizzo</i>	6,3bar / 91psi	6,3bar / 91psi
Air inlet / <i>Ingresso aria</i>	1/2" BSP	1/2" BSP
Inner hose diameter / <i>Diametro interno tubo</i>	16mm / 0,630 in	16mm / 0,630 in
Length (without envil) / <i>Lunghezza (escluso albero)</i>	296mm / 11,65 in	296mm / 11,65 in
Side to center / <i>Ingombro centro lato</i>	70mm / 2,76 in	70mm / 2,76 in
Direzione scarico aria / <i>Air exhaust direction</i>	frontal / <i>frontale</i>	frontal / <i>frontale</i>
Anvil type / <i>Tipo albero</i>	with ring with hole / <i>con anello, con foro</i>	with ring with hole / <i>con anello, con foro</i>
Hammer mechanism / <i>Tipo massa battente</i>	3-jaw / <i>3 griffe</i>	3-jaw / <i>3 griffe</i>

# MW256HL



SUITABLE FOR / *APPLICAZIONI*  
Trucks, Buses / *Camion, autobus* - Heavy vehicle / *Mezzi pesanti*

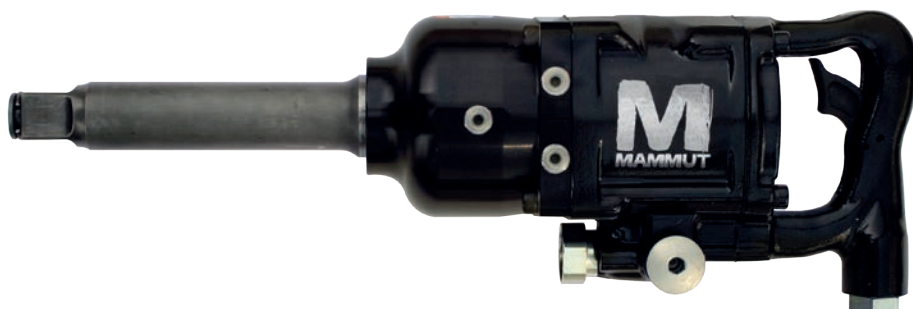

## ACCESSORIES AVAILABLE / *ACCESSORI DISPONIBILI*



Torque extensions / *Barre di torsione*



Impact sockets / *Chiavi a bussola*



Impact sockets / *Chiavi a bussola*

MW256HL	
Square drive / <i>Attacco quadro</i>	1"
Bolt range / <i>Capacità bullone</i>	M18-M39
Ultimate torque / <i>Coppia massima</i>	3185 Nm / 2357 ft-lb
Working torque / <i>Coppia raccomandata</i>	588 - 1666 Nm / 435-1233 ft-lb
Weight / <i>Peso</i>	9,48 Kg / 20,9 lbs
Working pressure / <i>Pressione di utilizzo</i>	6,3bar / 91psi
Air inlet / <i>Ingresso aria</i>	1/2" BSP
Inner hose diameter / <i>Diametro interno tubo</i>	13mm / 0,512 in
Length (without envil) / <i>Lunghezza (escluso albero)</i>	299mm / 11,77 in
Side to center / <i>Ingombro centro lato</i>	56mm / 2,20 in
Direzione scarico aria / <i>Air exhaust direction</i>	frontal / <i>frontale</i>
Anvil type / <i>Tipo albero</i>	with ring with hole / <i>con anello, con foro</i>
Hammer mechanism / <i>Tipo massa battente</i>	3-jaw / <i>3 griffe</i>

# MWHYDRO-T MWHYDRO-TS



SUITABLE FOR / *APPLICAZIONI*

Tire and maintenance truck / *Gommisti e officine autocarri*  
 - Road and services for trucks / *Servizio assistenza su strada e fuori sede* - Heavy duty vehicles / *Autocarri e mezzi pesanti* - Railway application / *Applicazioni ferroviarie*



TABELLA PRESSIONE-COPPIA AVVITAMENTO  
 TABLEAU PRESSION-COUPLE DE SERRAGE  
 PRESSURE-TIGHTENING TORQUE TABLE

Pressione Pressure [bar]	Coppia/Couple/Torque [Nm] ± 5%	
	● 32mm M22x1.5	● 33mm M22x1.5
60	295	314
70	373	382
80	422	436
90	490	510
100	549	566
110	578	627
120	635	684
130	682	741
140	734	798
150	786	855
160	835	912
170	887	942
180	940	997
190	991	1.052
200	1.045	1.100

Tempo di avvvitamento: 5 sec.  
 Temps de serrage / Tightening time: 5 sec.

	MWHYDRO-T	MWHYDRO-TS
Weight / peso	60 Kg / 132 lb	91,2 Kg / 201 lb
Power / potenza	2,2 Kw	2,2 Kw
Tension / tensione	220/400v trifase / 50/60 Hz	220/400v trifase / 50/60 Hz
Overall dimension / dimensione d'ingombro	610x690 mm	600x500 mm
Height / Altezza	1935 mm	1900 mm

**MWH340**  
**MWH340L**  
**MWH341**  
**MWH341L**

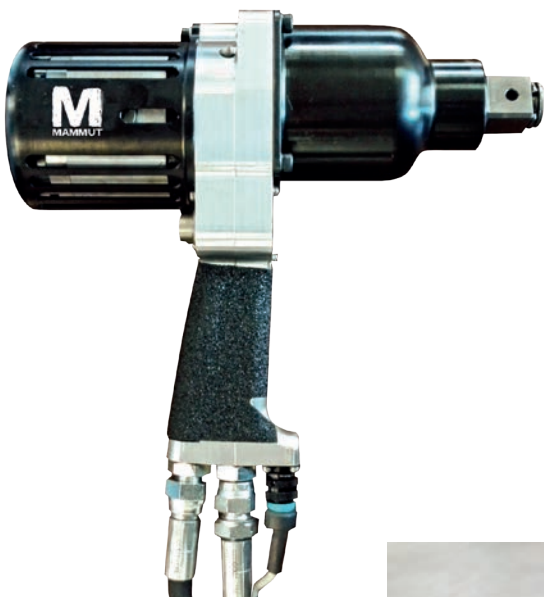

SUITABLE FOR / *APPLICAZIONI*

Tire and maintenance truck / *Gommisti e officine autocarri*  
 - Road and services for trucks / *Servizio assistenza su strada e fuori sede* - Heavy duty vehicles / *Autocarri e mezzi pesanti* - Railway application / *Applicazioni ferroviarie*

ACCESSORIES AVAILABLE / *ACCESSORI DISPONIBILI*



Torque extensions / *Barre di torsione*



Impact sockets / *Chiavi a bussola*



Impact sockets / *Chiavi a bussola*

	<b>MWH340</b>	<b>MWH340L</b>	<b>MWH341</b>	<b>MWH341L</b>
Square drive / <i>attacco quadro</i>	3/4"	3/4"	1"	1"
Bolt range / <i>capacità bullone</i>	M14-M24	M14-M24	M18-M33	M18-M33
Ultimate torque / <i>coppia massima</i>	3000Nm / 2220 ft-lb	3000Nm / 2220 ft-lb	3000Nm / 2220 ft-lb	3000Nm / 2220 ft-lb
Free speed / <i>Velocità libera</i>	2800 rpm	2800 rpm	2800 rpm	2800 rpm
Weight / <i>peso</i>	6,83 kg - 15.06 lbs	7,49 Kg - 16.51 lbs	6,90 kg - 15.21 lbs	7,57 kg - 16.69 lbs
Lenght (w/o envil) / <i>lunghezza (esc. albero)</i>	253mm / 9,96 in	253mm / 9,96 in	253mm / 9,96 in	253mm / 9,96 in
Side to center / <i>ingombro centro lato</i>	47 mm - 1.85 in	47 mm - 1.85 in	47 mm - 1.85 in	47 mm - 1.85 in
Max oil flow / <i>portata massima olio</i>	10 l/min	10 L/min	10 L/min	10 L/min

# MW217 ATEX MW251 ATEX



## SUITABLE FOR / APPLICAZIONI

Mine and oil field / *Miniere e giacimenti* - Construction site / *Cantieri* - Shipyard / *Costruzioni Navali* - Industrial assembly / *Montaggi industriali* - Agriculture / *Agricoltura* - Railway applications / *Applicazioni ferroviarie* - Military / *Settore militare*



	MW217-ATEX	MW251-ATEX
Square drive / <i>Attacco quadro</i>	3/4"	1"
Bolt range / <i>Capacità bullone</i>	M14 - M24	M18 - M39
Ultimate torque / <i>Coppia massima</i>	1600Nm / 1184 ft-lb	3038Nm / 2248 ft-lb
Working torque / <i>Coppia raccomandata</i>	320-907 Nm / 237-671 ft-lb	686 - 1568 Nm / 508 -1160 ft-lb
Weight / <i>Peso</i>	8,11 Kg / 17,88lbs	12,40 Kg / 27,34 lbs
Working pressure / <i>Pressione di utilizzo</i>	6,3bar / 91psi	6,3bar / 91psi
Air inlet / <i>Ingresso aria</i>	1/2" BSP	1/2" BSP
Inner hose diameter / <i>Diametro interno tubo</i>	13mm / 0,512in	13mm / 0,512in
Length (without envil) / <i>Lunghezza (escluso albero)</i>	182mm / 7,17 in	223mm / 8,78in
Side to center / <i>Ingombro centro lato</i>	47,5mm / 1,87in	56mm / 2,20 in
Direzione scarico aria / <i>Air exhaust direction</i>	handle / <i>impugnatura</i>	handle / <i>impugnatura</i>
Anvil type / <i>Tipo albero</i>	with ring with hole / <i>con anello, con foro</i>	with ring with hole / <i>con anello, con foro</i>
Hammer mechanism / <i>Tipo massa battente</i>	3-jaw / <i>3 griffe</i>	3-jaw / <i>3 griffe</i>



# MW256H ATEX MW362H ATEX



## SUITABLE FOR / APPLICAZIONI

Mine and oil field / *Miniere e giacimenti* - Infrastructure / *Infrastrutture* - Construction site / *Cantieri* - Shipyard / *Costruzioni Navali* - Industrial assembly / *Montaggi industriali* - Agriculture / *Agricoltura* - Railway applications / *Applicazioni ferroviarie* - Military / *Settore militare*



	MW256H-ATEX	MW362H-ATEX
Square drive / <i>Attacco quadro</i>	1"	1" 1/2
Bolt range / <i>Capacità bullone</i>	M18-M39	M24-M56
Ultimate torque / <i>Coppia massima</i>	3185 Nm / 2357 ft-lb	5933 Nm / 4390 ft-lb
Working torque / <i>Coppia raccomandata</i>	588 - 1666 Nm / 435-1233 ft-lb	1318-3296 Nm / 975-2439 ft-lb
Weight / <i>Peso</i>	12,58 Kg / 27,73 lbs	18,7 Kg / 41,23 lbs
Working pressure / <i>Pressione di utilizzo</i>	6,3bar / 91psi	6,3bar / 91psi
Air inlet / <i>Ingresso aria</i>	1/2" BSP	1/2" BSP
Inner hose diameter / <i>Diametro interno tubo</i>	13mm / 0,512 in	13mm / 0,512 in
Length (without envil) / <i>Lunghezza (escluso albero)</i>	299mm / 11,77 in	365mm / 14,37 in
Side to center / <i>Ingombro centro lato</i>	56mm / 2,20 in	60mm / 2,36 in
Direzione scarico aria / <i>Air exhaust direction</i>	frontal / <i>frontale</i>	frontal / <i>frontale</i>
Anvil type / <i>Tipo albero</i>	with ring with hole / <i>con anello, con foro</i>	with ring with hole / <i>con anello, con foro</i>
Hammer mechanism / <i>Tipo massa battente</i>	3-jaw / <i>3 griffe</i>	3-jaw / <i>3 griffe</i>



**M**  
MAMMUT



**MAMMUT HIGH QUALITY GROUND PROTECTION,  
STACK PADS, STABILITY SOLUTIONS:  
THE RIGHT PADS FOR EVERY SITUATION AND  
APPLICATION.**

**PIASTRE D'APPOGGIO, PIASTRE IMPILABILI E  
MODULI DI STABILITÀ MAMMUT:  
LE MIGLIORI SOLUZIONI PENSATE PER OGNI  
SITUAZIONE E UTILIZZO**

M-SP040010-01  
M-SP040020-01  
M-SP060015-01  
M-SP060025-01  
M-RP060040-01



**SUITABLE FOR / APPLICAZIONI**

Mine and oil field / *Miniere e giacimenti* - Construction site / *Cantieri* - Shipyard / *Costruzioni Navali* - Industrial assembly / *Montaggi industriali*



**GROUND PROTECTION**

Mammut outrigger pads are strong, rigid and easy equipment made of engineered thermo-plastic material. These pads spread the weight over a larger surface offering better support while also protecting the surface.

**Quality:**

In line with our philosophy, all Mammut outrigger pads are tested with the most sophisticated technologies to ensure the highest standards of safety. We deliver you tested and high quality equipment. We can assure you a safe operation of cranes and other vehicles when used according to the usage guidelines.

Mammut pads are:

- Ecological
- Easy to handle
- Flexible
- Water repellent
- Nearly unbreakable
- Anti-rust and anti-rot

**SAFETY ADVICE**

When you are cribbing, do not mix different blocks. To obtain a safe structure, the blocks need to be identical (same dimension, compression and friction). Please distribute the weight onto points of contact (\*) to obtain a maximum load capacity. The height of the stability tower can not be more than 3 times the width of the base! We strongly recommend to always use the jacks in combination with the stabilisation blocks for a double protection.

**PIASTRE D'APPOGGIO**

Le piastre stabilizzatrici "Mammut" sono attrezzature forti, rigide e di facile utilizzo, costruite in tecnopolimero. Il loro compito è di distribuire il peso su una superficie più ampia, per poter offrire un supporto migliore e proteggere il suolo.

**Qualità:**

In linea con la nostra filosofia, tutte le piastre stabilizzatrici Mammut sono testate con le più sofisticate tecnologie, al fine di garantire l'utilizzo sicuro. Vi consegniamo un prodotto testato e di alta qualità ed efficienza. Quando utilizzato in accordo con le normative d'utilizzo, siamo in grado di garantire la totale stabilità di gru e altri veicoli.

Le piastre stabilizzatrici Mammut sono:

- Ecologiche
- Facili da gestire
- Flessibili
- Idrorepellenti
- Quasi indistruttibili
- Antiruggine e anticorrosione

**NORME DI SICUREZZA**

Quando si vuole sovrapporre i moduli di stabilità, non mescolare diversi blocchi. Per ottenere struttura sicura, i blocchi devono essere identici (stessa dimensione, compressione e attrito). Si prega di distribuire il peso sui punti di contatto (\*) per ottenere una capacità massima di carico. L'altezza massima della "torre di stabilità" non può superare il triplo della larghezza della base! Si consiglia sempre, per una doppia protezione, di utilizzare i blocchi di stabilità insieme ai sollevatori oleopneumatici.

	M-SP040010-01	M-SP040020-01	M-SP060015-01	M-SP060025-01	M-RP060040-01
Forma / Shape	Quadrato / Square	Quadrato / Square	Quadrato / Square	Quadrato / Square	Rotondo / Round
Max Load Capacity / Capacità Massima	10 t	20 t	15 t	25 t	40 t
Lenght / Lunghezza	400mm	600mm	400mm	600mm	1000mm
Width / Larghezza	400mm	600mm	400mm	600mm	
Thickness / Spessore	40mm	40mm	60mm	60mm	60mm
Weight / Peso	12Kg/26,45lbs	14Kg/30,86lbs	13Kg/28,66lbs	16Kg/35,27lbs	46Kg/101,41lbs
Handles / Manico	1	1	1	1	2
Colour / Colore	Black / Nero	Black / Nero	Black / Nero	Black / Nero	Black / Nero

# M-STP805

# M-STP8010



#### SUITABLE FOR / APPLICAZIONI

Mine and oil field / *Miniere e giacimenti* - Construction site / *Cantieri* - Shipyard / *Costruzioni Navali* - Industrial assembly / *Montaggi industriali*



#### MAMMUT STACK PADS

Mammut stack pads are often used in combination with a larger outriggerpad on which those stack pads are piled up. Stack different pads in order to meet the requested height and enjoy the 2-sided antigrip finishing technology.

#### SAFETY ADVICE

When you are cribbing, do not mix different blocks. To obtain a safe structure, the blocks need to be identical (same dimension, compression and friction). Please distribute the weight onto points of contact (\*) to obtain a maximum load capacity. The height of the stability tower can not be more than 3 times the width of the base! We strongly recommend to always use the jacks in combination with the stabilisation blocks for a double protection.

#### PIASTRE IMPILABILI MAMMUT

Le piastre impilabili Mammut sono spesso usate in combinazione con una grande piastra d'appoggio stabilizzatrice sulla quale queste soluzioni vengono sovrapposte. E' possibile sovrapporre diverse piastre per ottenere l'altezza richiesta e sfruttare in pieno la tecnologia "antiscivolo" collocata su ambo i lati delle piastre.

#### NORME DI SICUREZZA

Quando si vuole sovrapporre i moduli di stabilità, non mescolare diversi blocchi. Per ottenere struttura sicura, i blocchi devono essere identici (stessa dimensione, compressione e attrito). Si prega di distribuire il peso sui punti di contatto (\*) per ottenere una capacità massima di carico. L'altezza massima della "torre di stabilità" non può superare il triplo della larghezza della base! Si consiglia sempre, per una doppia protezione, di utilizzare i blocchi di stabilità insieme ai sollevatori oleopneumatici.

	M-STP805	M-STP8010
Forma / Shape	Blocchi Sovrapponibili / Stack Pads	Blocchi Sovrapponibili / Stack Pads
Max Load Capacity / Capacità Massima	25 t	25 t
Length / Lunghezza	500mm	1000mm
Width / Larghezza	250mm	250mm
Thickness / Spessore	80mm	80mm
Weight / Peso	10 Kg / 22,04 lbs	19 Kg / 41,88 lbs
Handles / Manico	1	2
Colour / Colore	BLACK / NERO	BLACK / NERO

# M-SBB002 M-SBY002



## SUITABLE FOR / APPLICAZIONI

Mine and oil field / *Miniere e giacimenti* - Construction site / *Cantieri* - Shipyard / *Costruzioni Navali* - Industrial assembly / *Montaggi industriali*

### MAMMUT STABILITY SOLUTION

Mammut stability solutions are engineered to crib, block or stabilize the equipment, or vehicles.

Our stability solutions are designed as a system of interlocking blocks. These blocks are composed of 2 sides with notches and 2 sides with a pyramid surface. This system allows you to crib any vehicle or tool with no worry about safety and stability.

Mammut stability solution are:  
Lightweight and easy to handle  
Oil / Chemicals resistant  
Skidproof

### MODULI DI STABILITA' MAMMUT

*I moduli di stabilità Mammut hanno l'obiettivo di bloccare, incastrare o stabilizzare attrezzature o veicoli. I nostri moduli sono stati progettati seguendo un sistema di "blocchi ad incastro". Questi blocchi sono composti da 2 lati con tacche e 2 lati con superficie "a piramide". Ciò consente di bloccare qualsiasi mezzo senza nessuna preoccupazione circa la sicurezza o la stabilità.*

*I moduli di stabilità Mammut sono:*

- *Leggeri e maneggevoli*
- *Resistenti all'olio o a componenti chimici*
- *Antiscivolo*

### SAFETY ADVICE

When you are cribbing, do not mix different blocks. To obtain a safe structure, the blocks need to be identical (same dimension, compression and friction). Please distribute the weight onto points of contact (\*) to obtain a maximum load capacity. The height of the stability tower can not be more than 3 times the width of the base! We strongly recommend to always use the jacks in combination with the stabilisation blocks for a double protection.

### NORME DI SICUREZZA

*Quando si vuole sovrapporre i moduli di stabilità, non mescolare diversi blocchi. Per ottenere struttura sicura, i blocchi devono essere identici (stessa dimensione, compressione e attrito). Si prega di distribuire il peso sui punti di contatto (\*) per ottenere una capacità massima di carico. L'altezza massima della "torre di stabilità" non può superare il triplo della larghezza della base! Si consiglia sempre, per una doppia protezione, di utilizzare i blocchi di stabilità insieme ai sollevatori oleopneumatici.*

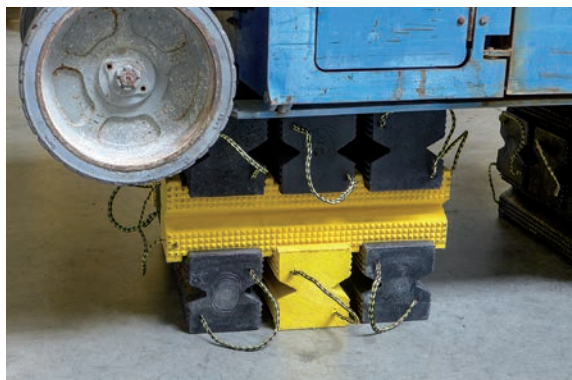

## M-SBB002 M-SBY002

Forma / Shape	Stabilty Solution - Hybrid Block
Max Load Capacity / Capacità Massima	4,8N/mm2
Lenght / Lunghezza	610mm
Width / Larghezza	152mm
Thickness / Spessore	178mm
Weight / Peso	11,3 Kg / 24,91 lbs
Handles / Manico	2
Colour / Colore	BLACK / NERO

The Sava logo is displayed in white text on a green rectangular background. It includes a small icon of a tire tread to the right of the brand name.

**AUTHORIZED DEALER**

## **LIFTING BAGS, RESCUE KITS**

Specific for **mining, industrial**  
and **military** applications

EN13731 Certified

## **CUSCINI DI SOLLEVAMENTO, KIT RESCUE**

Specifici per i settori **minerario,**  
**industriale** e **militare**

Conformi alla normativa EN13731

The MAMMUT logo features a large, stylized white letter 'M' with a distressed, textured appearance. Below the 'M', the word 'MAMMUT' is written in a clean, white, sans-serif font.

**SEE OUR FULL SAVA®  
PRODUCTS OFFER**

[www.cattini.eu/mammut/lifting-bags](http://www.cattini.eu/mammut/lifting-bags)

**Cattini**  
OLEOPNEUMATICA

The data reported in this catalogue are not binding. Cattini Oleopneumatica S.r.l. reserves the right to change specifications without notice.  
*I dati riportati nella seguente pubblicazione non sono impegnativi. Cattini Oleopneumatica S.r.l. si riserva di apportare modifiche senza preavviso.*



**M**  
MAMMUT

**Cattini**  
OLEOPNEUMATICA

VIA G. VERDI, 41  
42049 GATTATICO (Reggio Emilia) - ITALY  
PH. +39 0522 909750 - FAX +39 0522 909875

[www.mammutjacks.com](http://www.mammutjacks.com)  
[info@cattini.eu](mailto:info@cattini.eu)



Certificato No. 112560A

member of  
**AE** AUTOMOTIVE  
EQUIPMENT  
GROUP

V51552300300